

TRIUMPH™

5.3e

Owner's Manual Triumph 5.3e Elliptical

Customer Service
(888) 340-0482

Keys Fitness Products
4009 Distribution Drive
Suite 250
Garland, TX 75041

www.keysfitness.com



Table of Contents

Important Safety Information	3
Before You Start	4
Assembly	5-10
Exploded View	11
Parts List	12
Moving Instructions	13
Warm Up Exercises	14
Target Heart Rate Zone	15-16
Warranty	17

Important Safety Information

WARNING! Before using this unit or starting any exercise program, consult your physician. This is especially important for persons over the age of 35 and/or persons with pre-existing health problems. The manufacturer or distributor assumes no responsibility for personal injury or property damage sustained by or through the use of this product.

WARNING! To reduce the risk of electrical shock, burns, fire, or other possible injuries to the user, it is important to review this manual and the following precautions **before** operation.

SAFETY PRECAUTIONS AND TIPS

1. It is the owner's responsibility to ensure that all users of this unit have read the Owner's Manual and are familiar with warnings and safety precautions.
2. This unit has a user maximum capacity of **250** pounds.
3. The unit should only be used on a level surface and is intended for indoor use only. The unit should not be placed in a garage, patio, or near water and should never be used while you are wet. Keys recommends a mat be placed under the unit to protect floor or carpet and for easier cleaning.
4. Wear comfortable, good-quality walking or running shoes and appropriate clothing. Do not use the unit with bare feet, sandals, socks or stockings.
5. Always examine your unit before using to ensure all parts are in working order.
6. Allow the unit to fully stop before dismounting.
7. Pets should never be allowed near the unit.
8. Do not leave children unsupervised near or on the unit.
9. Never operate the unit where oxygen is being administered, or where aerosol products are being used.
10. Never insert any object or body parts into any opening.
11. For safety and to prevent damage to your unit, no more than one person should use the unit at a time.
12. Failure to follow these instructions will void the unit warranty.

Before You Start

Thank you for purchasing the **Triumph 5.3e Elliptical!** This quality product you have chosen was designed to meet your needs for cardiovascular exercise. Before you start, please read the Owner's Manual and become familiar with the operation of your new unit.

Remember to take the time to perform the stretching exercises provided to avoid injury.

If you are taking medication, consult your physician to see if the medication will affect your exercise heart rate.

If you have heart problems, you are not active, and/or are over the age of 35 years, do not use the pre-set programs or start an exercise program without first contacting and receiving approval from your physician.

To avoid the risk of electrical shock, always keep the console dry. Do not spill liquids on the console. Keys Fitness recommends a sealed water bottle for beverages consumed while using the unit.

Please review the following drawing below to familiarize yourself with the listed parts.

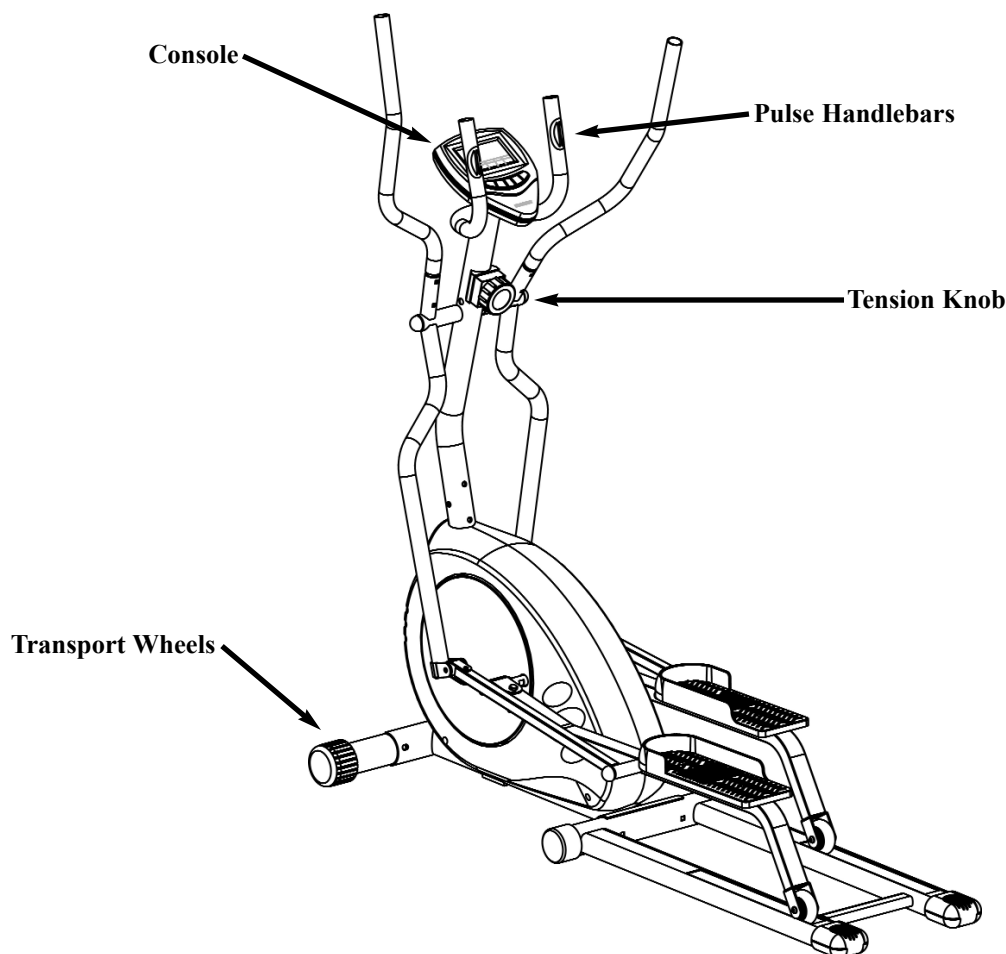

Assembly

Assembly Parts

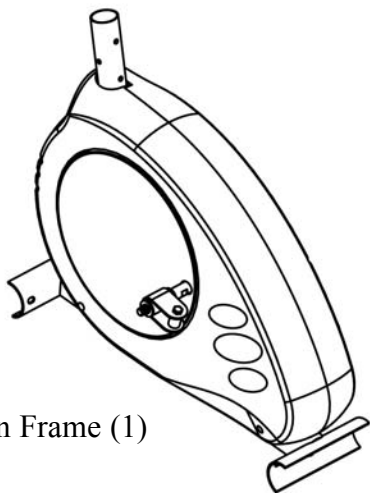

Main Frame (1)

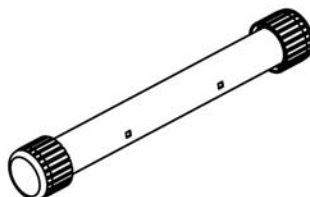

Front Stabilizer (54)

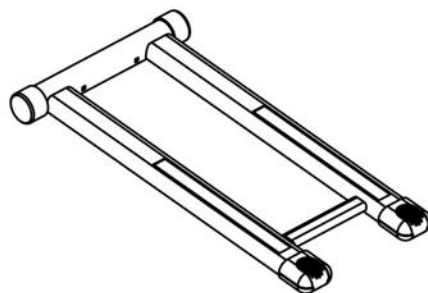

Rail Tube (2)

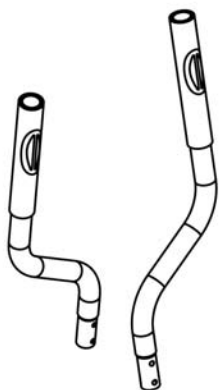

L&R Upper Handlebars (7a&7b)



Console Tube (3)



Console (9)

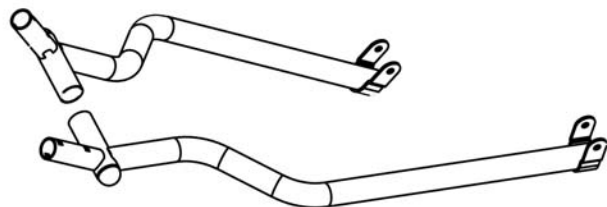

L&R Lower Handlebars (6a&6b)

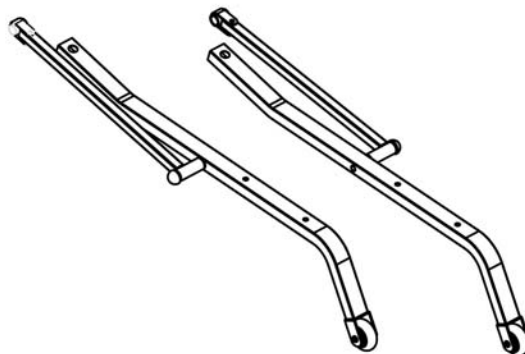

L&R Foot Pedals (4a&4b)

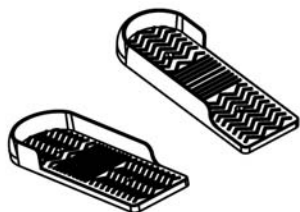

L&R Pedals (5a&5b)

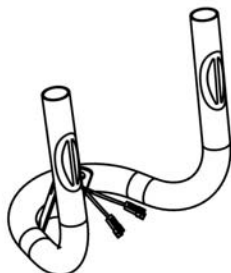

Pulse Handlebars (85)

Assembly

Assembly Accessories

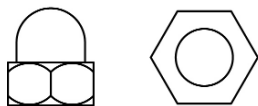

M8 Cap Nut (33) - 4



Arc Washer (34) - 12

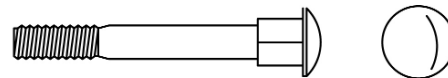

Carriage Bolt (35) - 4



Hex Head Bolt (47) - 4

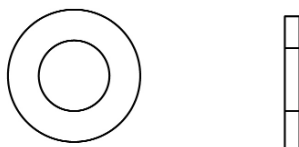

Washer (48) - 4

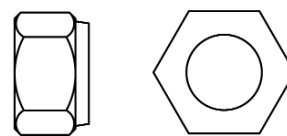

Nylon Locknut (49) - 4

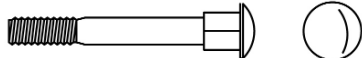

Carriage Bolt (62) - 4

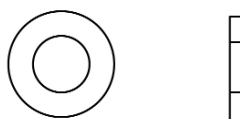

Washer (63) - 4



M6 Cap Nut (64) - 4



HEX HEAD BOLT (65) - 8

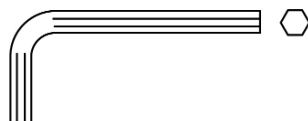

ALLEN WENCH

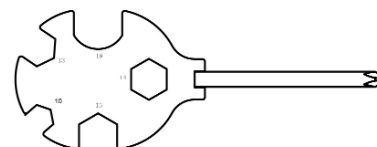

SCREW DRIVER

Assembly

INSTRUCTIONS FOR ASSEMBLY:

Unpack the box in a clear area. Check to make sure all components are present and in good condition. Do not dispose of the packing material until the assembly is completed. Tools have been provided for you to use when assembling the product. If you need assistance please go to our website at www.keysfitness.com or call 888-340-0482.

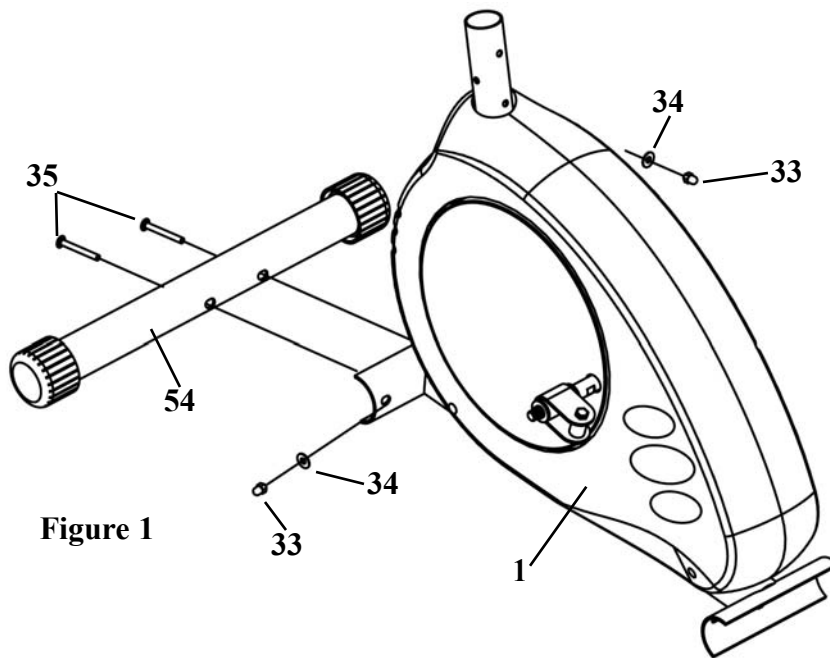

Figure 1

1. Attach the *Front Stabilizer* (54) onto *Main Frame* (1) and secure in place with two *Carriage Screws* (35), two *Arc Washers* (34), and two *Cap Nuts* (33).

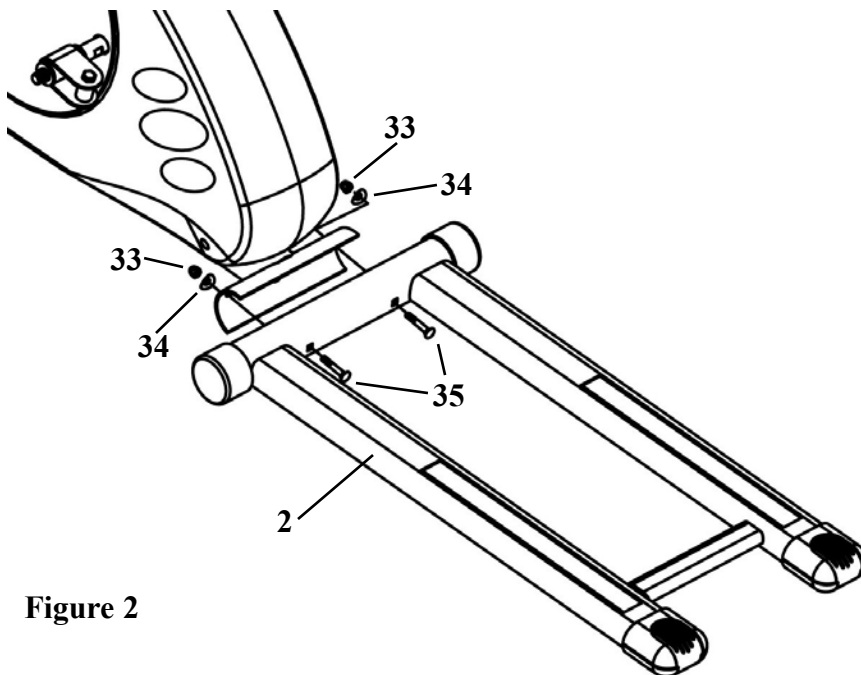

Figure 2

2. Install the *Rail Tube* (2) to the *Main Frame* (1) and secure it with two *Carriage Bolts* (35), two *Washers* (34), and two *Cap Nuts* (33).

Assembly

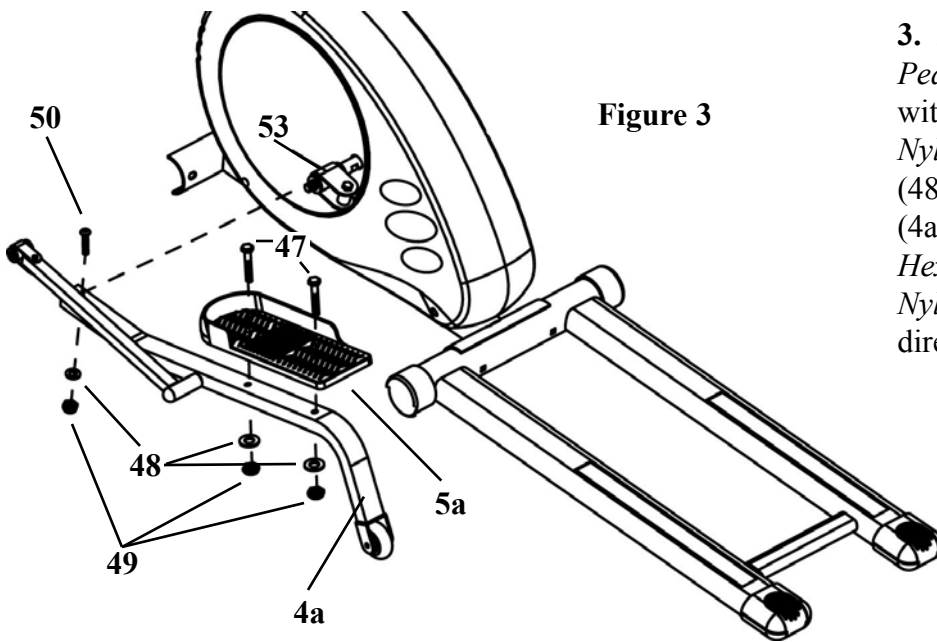
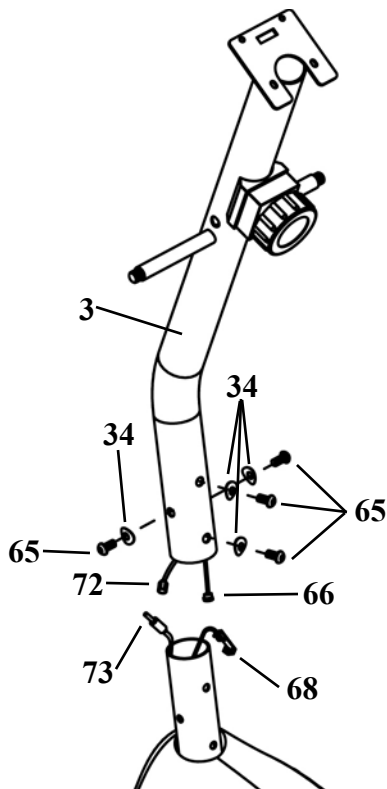

Figure 3

3. Attach the *Left Pedal* (5a) to *Left Pedal Tube* (4a) and secure in place with two *Hex Head Bolts* (47), two *Nylock Nuts* (49), and two *Washers* (48). Next, insert the *Left Pedal Tube* (4a) into the *U Bracket* (53) and use *Hex Head Bolt* (50), *Washer* (48), and *Nylock Nut* (49). Repeat previous directions to complete the right side.

Figure 4



4. Connect the *Extension Wire* (72) to *Sensor Wire* (73). Next, connect the *Tension Cable* (68) to the *Tension Knob* (66). **(Refer to Figure 4a on the next page)** Slide the *Console Tube* (3) onto the *Main Frame* (1) and secure in place using four *Washers* (34) and four *Hex Head Bolt* (65).

Assembly

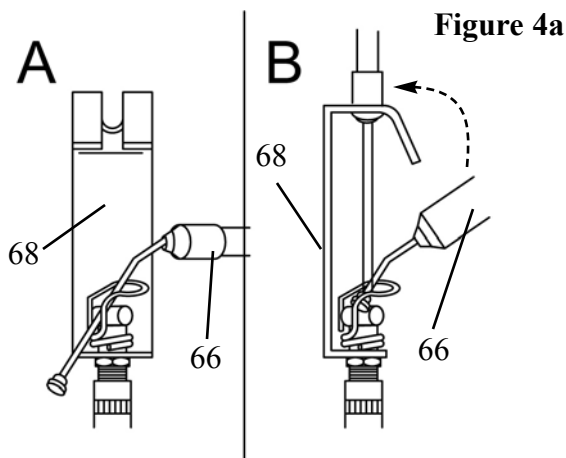

Step 1: With the *Tension Knob* (66) on the lowest resistance setting number 1, insert the ball end of the tension knob cable into the spring hook on *Tension Cable* (68).

Refer to Picture A for Step 1.

Step 2: Take the tension knob cable and pull it up and between the gap of the bracket on the *Tension Cable* (68).

Refer to Picture B for Step 2.

You can raise the tension by turning the *Tension Knob* (66) clockwise.

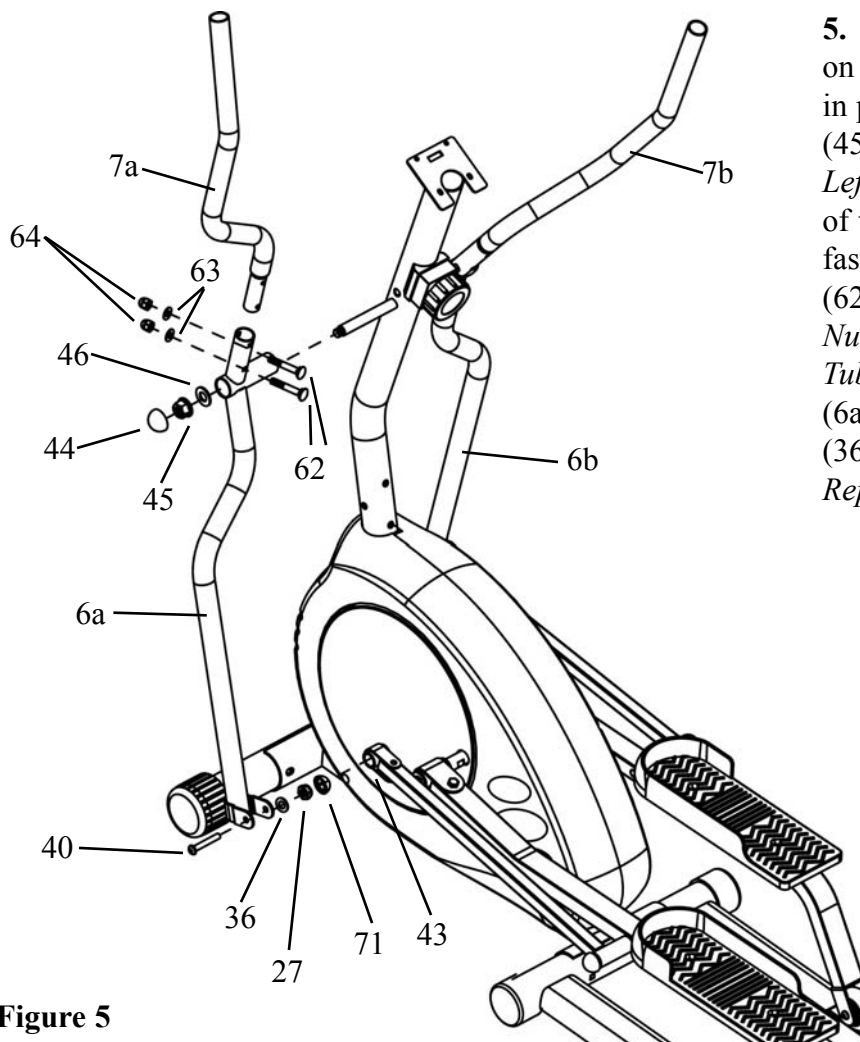

Figure 5

5. Slide the *Left Lower Handlebar* (6a) on to the *Console Tube* (3) and secure it in place using *Washer* (46), *Nylock Nut* (45), and *Nut Cap* (44). Next, slide the *Left Upper Handlebar* (7a) into the top of the *Left Lower Handlebar* (6a) and fasten in place using two *Carriage Bolts* (62), two *Washers* (63), and two *Cap Nuts* (64). Assemble the *Connecting Tube* (43) and the *Lower Left Handlebar* (6a) using *Hex Head Bolt* (40), *Washer* (36), *Nylock Nut* (27), and *Nut Cap* (71). Repeat step to complete the right side.

Assembly

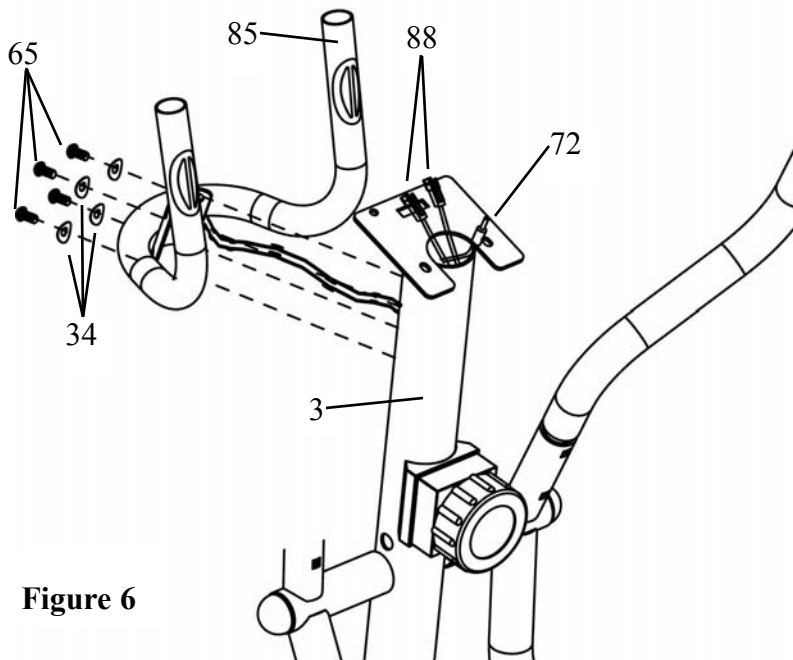

Figure 6

6. Insert the *Pulse Wires* (88) into the large hole at the front of the *Console Tube* (3) and pull the wires through the hole at the top of the tube. Secure the *Pulse Handlebar* (85) to the *Console Tube* (3) using four *Arc Washers* (34) and four *Hex Head Bolts* (65).

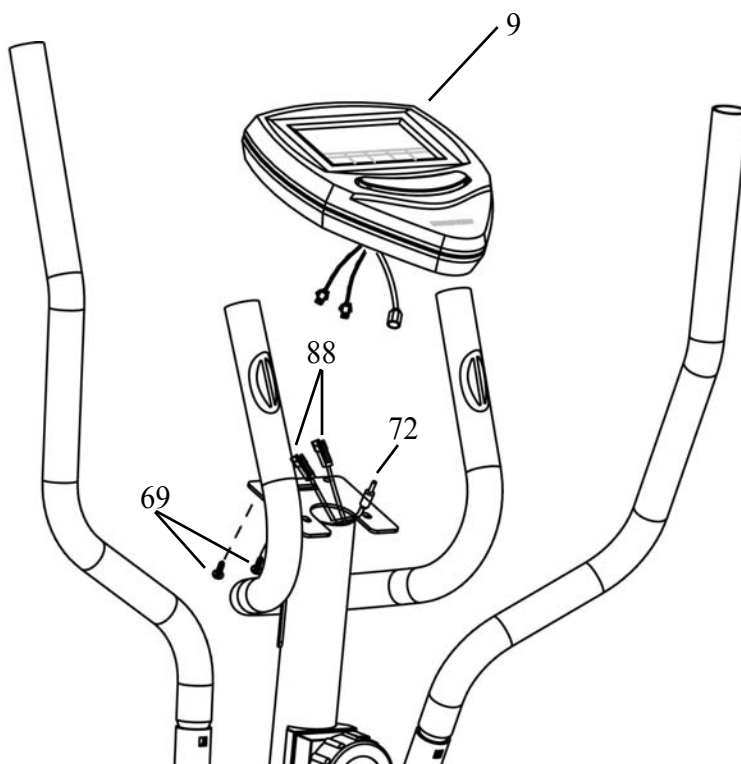

Figure 7

7. Connect the *Sensor Wire* (72) and the *Pulse Wires* (88) to the *Console* (9). Then attach the *Console* (9) to the top of the *Console Tube* (3) and secure it in place using four *Screws* (69).
Note: The four Screws (69) will already be installed into the back of the Console (9) when you remove it from the box.

Congratulations!

You have completed the assembly of your new Triumph 5.3e Elliptical.

Exploded View

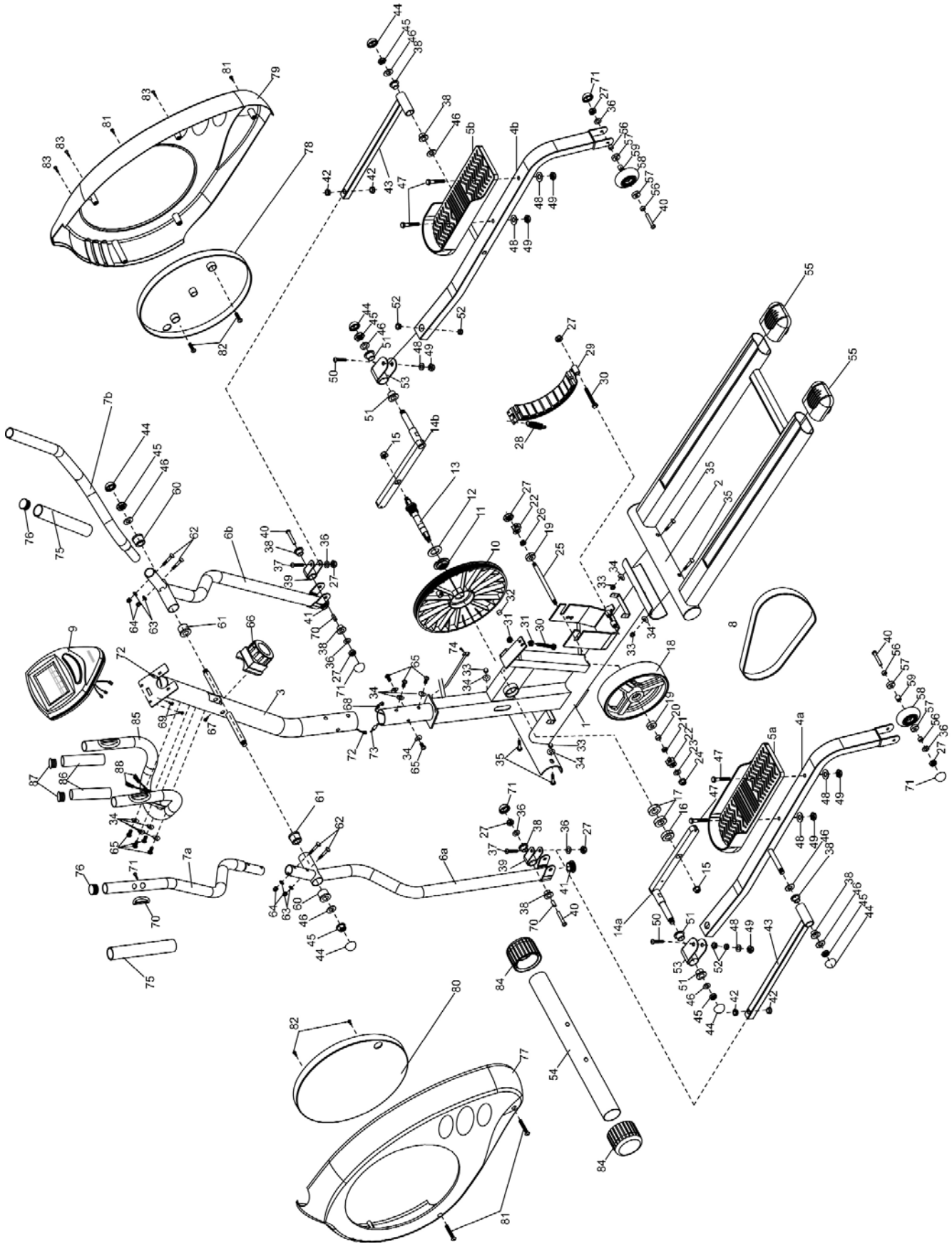

Parts List

TRI5.3e Parts List Rev B

REF #	PART #	DESCRIPTION	QTY	REF #	PART #	DESCRIPTION	QTY
1	323-00270	MAIN FRAME TRI-5.3E	1	44	302-01110	NUT CAP TRI-5.3E	6
2	323-00271	RAIL TUBE TRI-5.3E	1	45	302-01111	NYLOCK NUT TRI-5.3E	6
3	323-00272	CONSOLE TUBE TRI-5.3E	1	46	302-01112	WASHER 13*26*2 TRI-5.3E	8
4a	323-00273	LEFT PEDAL TUBE TRI-5.3E	1	47	302-01113	HEX HEAD BOLT 3/8"*45 TRI-5.3E	4
4b	323-00274	RIGHT PEDAL TUBE TRI-5.3E	1	48	302-01114	WASHER 10*26*2 TRI-5.3E	6
5a	323-00275	LEFT PEDAL TRI-5.3E	1	49	302-01115	NYLOCK NUT 3/8" TRI-5.3E	6
5b	323-00276	RIGHT PEDAL TRI-5.3E	1	50	302-01116	HEX HEAD BOLT 3/8"*50 TRI-5.3E	2
6a	323-00277	LEFT LOWER HANDLEBAR TRI-5.3E	1	51	302-01117	BUSHING CHROME TRI-5.3E #51	4
6b	323-00278	RIGHT LOWER HANDLEBAR TRI-5.3E	1	52	302-01118	BUSHING CHROME TRI-5.3E #52	4
7a	323-00279	LEFT UPPER HANDLEBAR TRI-5.3E	1	53	319-00131	U BRACKET, TRI-5.3E	2
7b	323-00280	RIGHT UPPER HANDLEBAR TRI-5.3E	1	54	323-00283	FRONT STABILIZER TRI-5.3E	1
8	304-00007	BELT, J6-400	1	55	306-00473	MOVING TUBE CAP, TRI-5.3E/8.3E	2
9	307-00068	CONSOLE, TRI 5.3	1	56	302-01119	SMALL SPACER TRI-5.3E	4
10	311-00063	PULLEY, TRI-5.3E	1	57	331-00082	BEARING TRI-5.3E #57	4
11	331-00080	OUTSIDE BEARING COLLAR TRI-5.3E	1	58	306-00474	WHEEL, TRI-5.3E/8.3E	2
12	302-01086	BIG WASHER TRI-5.3E	1	59	302-01120	BIG SPACER TRI-5.3E	2
13	330-00063	AXLE FOR PULLEY, TRI-5.3E	1	60	306-00481	PLASTIC ROLL TRI-5.3E	2
14a	330-00064	LEFT CRANK, TRI-5.3E	1	61	306-00482	PLASTIC ROLL TRI-5.3E	2
14b	330-00065	RIGHT CRANK, TRI-5.3E	1	62	302-01121	CARRIAGE BOLT M6*35 TRI-5.3E	4
15	302-01087	NYLOCK NUT M10 TRI-5.3E	2	63	302-01122	WASHER 6*13*1 TRI-5.3E	4
16	302-01088	C CLIP TRI-5.3E	1	64	302-01123	CAP NUT M6 TRI-5.3E	4
17	331-00009	BEARING 6003ZZ	2	65	302-01124	HEX HEAD BOLT M8*15	8
18	311-00064	FLYWHEEL, TRI-5.3E	1	66	310-00157	TENSION KNOB, TRI-5.3E	1
19	331-00005	BEARINGS 6000Z	2	67	302-01125	BOLT TRI-5.3E #66	1
20	302-01089	SPACER FOR FLYWHEEL TRI-5.3E	1	68	310-00158	TENSION CABLE, TRI-5.3E	1
21	302-01090	BC NUT 3/8" TRI-5.3E	1	69	302-01126	BOLT TRI-5.3E #69	2
22	302-01091	ZIP SET TRI-5.3E	2	70	302-01127	SPACER 12.7*37.1 TRI-5.3E	2
23	302-01092	WASHER 10*19*1.5 TRI-5.3E	1	71	302-00173	NUT CAP	4
24	302-01093	NUT 3/8" TRI-5.3E	1	72	313-00125	EXTENSION WIRE, TRI-5.3E	1
25	330-00066	AXLE FOR FLYWHEEL, TRI-5.3E	1	73	313-00126	SENSOR WIRE, TRI-5.3E	1
26	331-00081	GREASED BEARING TRI-5.3E #26	1	74	302-01129	SCREW M4*11 TRI-5.3E	1
27	302-01094	NYLOCK NUT M8 TRI-5.3E	8	75	310-00159	FOAM GRIP, TRI-5.3E	2
28	302-01095	ARC SPRING TRI-5.3E	1	76	306-00431	HANDLEBAR CAP, TRI-5.3E, 8.3E	2
29	302-01096	ARC PLATE TRI-5.3E	1	77	306-00475	LEFT HOUSING, TRI-5.3E/8.3E	1
30	302-01097	HEX HEAD BOLT M8*60 TRI-5.3E	2	78	306-00476	RIGHT ROUND COVER, TRI-5.3E/8.3E	1
31	302-01098	NUT M8 TRI-5.3E	2	79	306-00477	RIGHT HOUSING TRI-5.3E	1
32	302-01099	MAGNET TRI-5.3E	1	80	306-00478	LEFT ROUND COVER TRI-5.3E	1
33	302-01100	CAP NUT M8 TRI-5.3E	4	81	302-01130	SCREW M4*16 TRI-5.3E	4
34	302-01101	ARC WASHER 8*19*1.5 TRI-5.3E	12	82	302-01131	BOLT M5*12 TRI-5.3E	4
35	302-01102	CARRIAGE BOLT M8*60 TRI-5.3E	4	83	302-01132	SCREW M4*44 TRI-5.3E	3
36	302-01103	WASHER 8*19*1.5 TRI-5.3E	6	84	306-00479	WHEEL CAP, TRI-5.3E	2
37	302-01104	HEX HEAD BOLT M8*40 TRI-5.3E	2	85	323-00284	PULSE HANDLEBAR TRI-5.3E	1
38	302-01105	BUSHING CHROME TRI-5.3E	8	86	310-00160	FOAM GRIP, TRI-5.3E	2
39	323-00281	U CONNECT TUBE TRI-5.3E	2	87	306-00480	HANDLEBAR CAP TRI-5.3E	2
40	302-01107	HEX HEAD BOLT M8*55 TRI-5.3E	4	88	313-00127	HAND PULSE WIRE, TRI-5.3E	2
41	302-01108	LOWER HANDLEBAR CAP TRI-5.3E	2	#	302-01134	BOLT PACK TRI-5.3E	1
42	302-01109	BUSHING CHROME TRI-5.3E	4	#	315-00021	OWNER'S MANUAL TRI-5.3E	1
43	323-00282	CONNECTING TUBE TRI-5.3E	2				

Moving Instructions

CAUTION! TO REDUCE THE POSSIBILITY OF INJURY WHILE LIFTING, BEND YOUR LEGS AND KEEP YOUR BACK STRAIGHT. AS YOU LEAN THE UNIT, LIFT USING YOUR LEGS, NOT YOUR BACK.

Kneel down and firmly grasp the rear rail tube support with both hands. Carefully stand up and bring the rear of the unit in the air. Make sure you use your legs when standing up, not your back. Using extreme caution, move the unit to the desired location as shown in Figure 1. Do not attempt to move the unit over an uneven or rough surface.

Figure 1

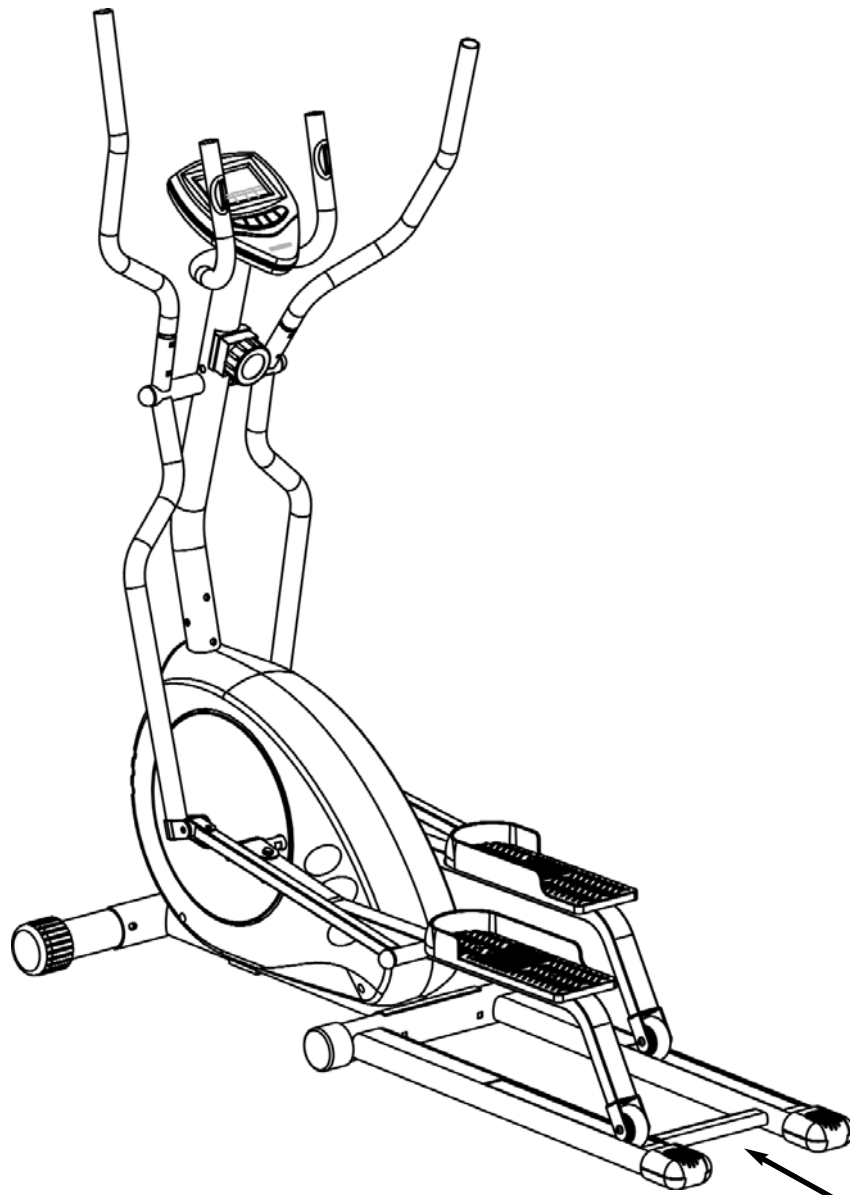

Rear Rail Tube Support

Warm Up Exercises

EXERCISE GUIDELINES

WARNING! Before beginning this or any exercise program, you should consult your physician. This is especially important for individuals over the age of 35 or individuals with pre-existing health problems.

Warming up prepares the body for the exercise by increasing circulation, supplying more oxygen to the muscles and raising body temperature. Begin each workout with 5 to 10 minutes of stretching and light exercise to warm up. The photos on this page show several forms of basic stretching you may perform before your workouts. In order to achieve an adequate warm-up, perform each stretch three times.

TOE TOUCH STRETCH

Stand bending your knees slightly and slowly bend forward from your hips. Allow your back and shoulders to relax as you reach down toward your toes as far as possible. Hold for 15 counts, then relax. This will stretch your hamstrings, back of knees, and back.



HAMSTRING STRETCH

Sit with one leg extended. Bring the sole of the opposite foot toward you and rest it against the inner thigh of your extended leg. Reach toward your toes as far as possible. Hold for 15 counts, then relax. This will stretch your hamstrings, lower back, and groin.



CALF/ACHILLES STRETCH

With one leg in front of the other, reach forward and place your hands against a wall. Keep your back leg straight and your back foot flat on the floor. Bend your front leg, lean forward and move your hips toward the wall. Hold for 15 counts, then relax. To cause further stretching of the Achilles tendon, bend your back leg as well. This will stretch your calves, Achilles tendons, and ankles.

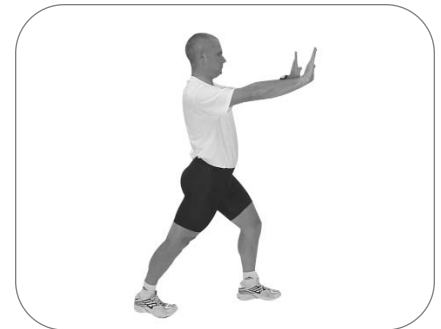

QUADRICEPS STRETCH

With one hand against a wall for balance, reach back and grasp one foot with your other hand. Bring your heel as close to your buttocks as possible. Hold for 15 counts, then relax. This will stretch your quadriceps and hip muscles.

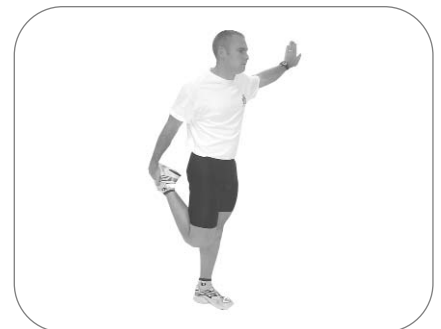

INNER THIGH STRETCH

Sit with the soles of your feet together and your knees outward. Pull your feet toward your groin area as far as possible. Hold for 15 counts, then relax. This will stretch your quadriceps and hip muscles.

Monitoring Your Heart Rate

Monitoring Your Heart Rate

To obtain the greatest cardiovascular benefits from your exercise workout, it is important to work within your target heart rate zone. The American Heart Association (AHA) defines this target as 60%-75% percent of your maximum heart rate.

Your maximum heart rate may be roughly calculated by subtracting your age from 220. Your maximum heart rate and aerobic capacity naturally decreases as you age. This may vary from one person to another, but use this number to find your approximate effective target zone. For example, the maximum heart rate for an average 40 year-old is 180 bpm. The target heart rate zone is 60%-75% of 180 or 108-135 bpm. See *Fitness Safety* below.

Before beginning your workout, check your normal resting heart rate. Place your fingers lightly against your neck, or against your wrist over the main artery. After finding your pulse, count the number of beats in 10 seconds. Multiply the number of beats by six to determine your pulse rate per minute. We recommend taking your heart rate at these times; at rest, after warming up, during your workout and two minutes into your cool down, to accurately track your progress as it relates to better fitness.

During your first several months of exercising, the AHA recommends aiming for the lower part of the target heart rate zone-60%, then gradually progressing up to 75%.

According to the AHA, exercising above 75% of your maximum heart rate may be too strenuous unless you are in top physical condition. Exercising below 60% of your maximum will result in minimal cardiovascular conditioning.

Check your pulse recovery rate – If your pulse is over 100 bpm five minutes after you stop exercising, or if it's higher than normal the morning after exercising, your exertion may have been too strenuous for your current fitness level. Rest and reduce the intensity next time.

Fitness Safety *The target heart rate chart indicates average rate zones for different ages. A variety of different factors (including medication, emotional state, temperature and other conditions) can affect the target heart rate zone that is best for you. Your physician or health care professional can help you determine the exercise intensity that is appropriate for your age and condition.*

(MHR) = Maximum Heart Rate

(THR) = Target Heart Rate

$220 - \text{age} = \text{maximum heart rate (MHR)}$

$\text{MHR} \times .60 = 60\% \text{ of your maximum heart rate.}$

$\text{MHR} \times .75 = 75\% \text{ of your maximum heart rate.}$

For example, if you are 30 years old, your calculations will be as follows:

$220 - 30 = 190$

$190 \times .60 = 114 \text{ (low end or 60\% of MHR)}$

$190 \times .75 = 142 \text{ (high end or 75\% of MHR)}$

30 year-old (THR) Target Heart Rate would be 114-142

See Heart Rate Table for additional calculations.

Monitoring Your Heart Rate

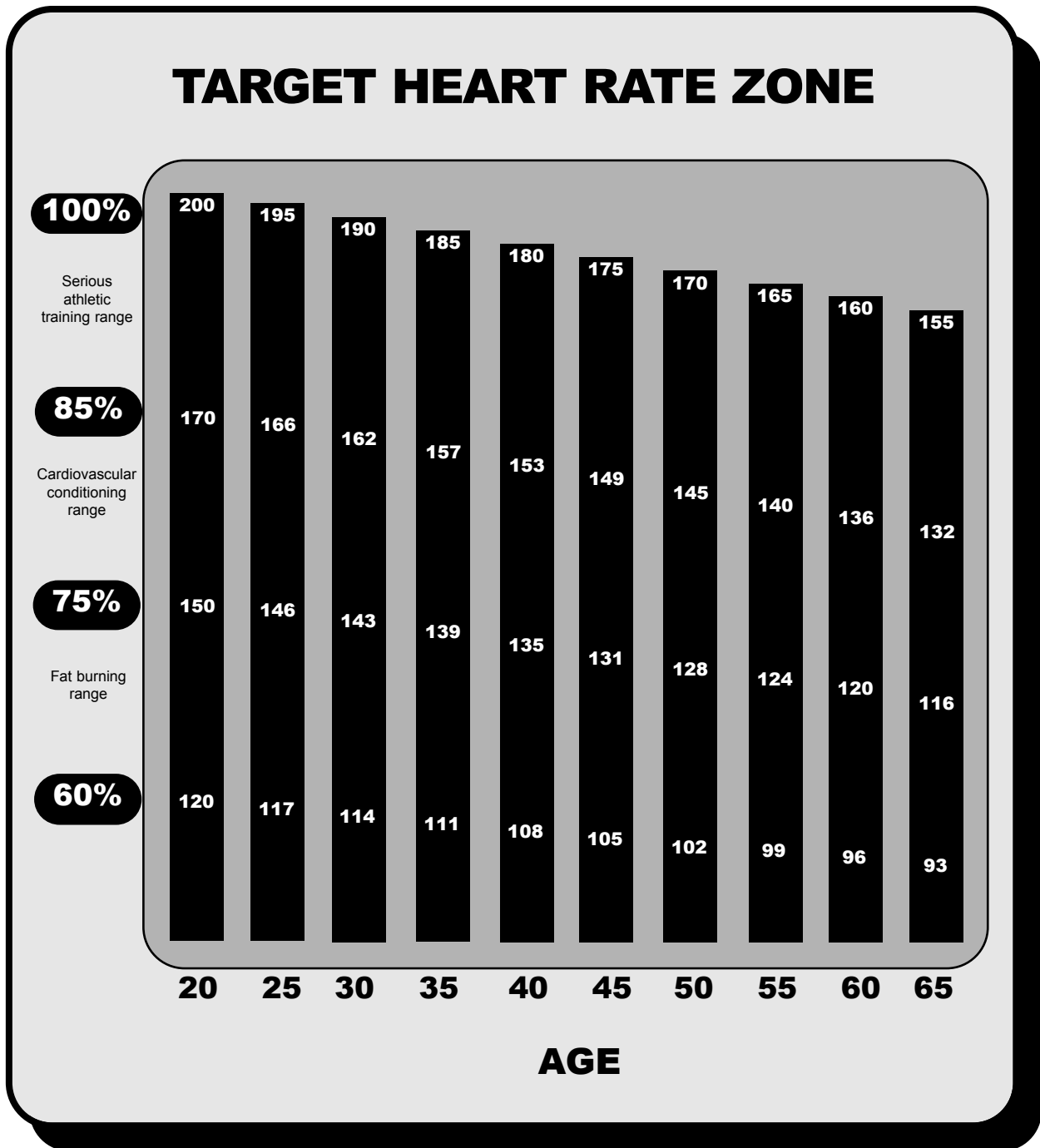

Warranty Information

**Tri 5.3e Elliptical is designed and distributed by KEYS FITNESS PRODUCTS, LP – LIMITED WARRANTY
PLEASE CONSULT YOUR PHYSICIAN BEFORE USING THIS PRODUCT.**

This Limited Warranty applies in the United States and Canada to products manufactured or distributed by Keys Fitness Products, LP (“Keys”) under the KEYS brand name. The warranty period on the Tri 5.3e to the original purchaser is (1) year parts.

Keys warrants that the Product you have purchased for non-commercial, personal, family, or household use from Keys or from an authorized Keys reseller is free from defects in materials or workmanship under normal use during the warranty period. Your sales receipt, showing the date of purchase of the Product, is your proof of the date of purchase. This warranty only extends to you, the original purchaser. It is not transferable to anyone who subsequently purchases the Product from you. It excludes expendable parts. This Limited Warranty becomes VALID ONLY if the unit is assembled/installed by a Keys Fitness authorized dealer/technician unless otherwise authorized by Keys Fitness in writing (if anyone other than a Keys Fitness authorized dealer/technician assembles a Keys Fitness unit the warranty will be void unless accompanied by written authorization by Keys Fitness).

During the warranty period Keys will at no additional charge, repair or replace (at Keys’ option) the product if it becomes defective, malfunctions, or otherwise fails to conform with this Limited Warranty under normal non-commercial, personal, family or household use. In repairing the Product, Keys may replace defective parts, or at the option of Keys, serviceable used parts that are equivalent to new parts in performance. All exchanged parts and Products replaced under this warranty will become the property of Keys. Keys reserves the right to change manufacturers of any part to cover any existing warranty.

To obtain warranty service, you must contact a Keys authorized service technician or Keys Fitness at our phone numbers located in this manual. Any parts determined to be defective must be returned to Keys to obtain warranty service. You must prepay any shipping charges, export taxes, custom duties and taxes, or any other charges associated with transportation of the parts or Product. In addition, you are responsible for insuring any parts or Product shipped or returned. You assume the risk of loss during shipment. You must present Keys with proof-of-purchase documents (including the date of purchase). Any evidence of alteration, erasing or forgery of proof-of-purchase documents will be cause to void this Limited Warranty.

This warranty does not extend to any product not purchased from Keys or from an authorized Keys reseller. This Limited Warranty does not extend to any Product that has been damaged or rendered defective; (a) as a result of accident, misuse, or abuse; (b) by the use of parts not manufactured or sold by Keys; (c) by modification of the Product or normal wear and tear; (d) operation on incorrect power supplies; or (e) as a result of service by anyone other than Keys, or an authorized Keys warranty service provider. Product on which the serial number has been defaced or removed is not eligible for warranty service. Should any Product be submitted for warranty service be found ineligible therefore, an estimate of repair cost will be furnished and the repair will be made if requested by you upon Keys’ receipt of payment or acceptable arrangements for payment.

EXCEPT AS EXPRESSLY SET FORTH IN THIS WARRANTY, KEYS MAKES NO OTHER WARRANTIES, EXPRESSED OR IMPLIED, INCLUDING ANY IMPLIED WARRANTIES OF MERCHANTABILITY AND FITNESS FOR A PARTICULAR PURPOSE. KEYS EXPRESSLY DISCLAIMS ALL WARRANTIES NOT STATED IN THIS LIMITED WARRANTY. ANY IMPLIED WARRANTIES THAT MAY BE IMPOSED BY LAW ARE LIMITED TO THE TERMS OF THIS LIMITED WARRANTY. NEITHER KEYS NOR ANY OF ITS AFFILIATES SHALL BE RESPONSIBLE FOR INCIDENTAL OR CONSEQUENTIAL DAMAGES. SOME STATES DO NOT ALLOW LIMITATIONS ON HOW LONG AN IMPLIED WARRANTY LASTS OR THE EXCLUSION OR LIMITATION OF INCIDENTAL OR CONSEQUENTIAL DAMAGES, SO THE ABOVE LIMITATIONS OR EXCLUSION MAY NOT APPLY TO YOU.

This Limited Warranty gives you specific legal rights and you may also have other rights that may vary from state to state. This is the only express warranty applicable to Keys-branded products. Keys neither assumes nor authorizes anyone to assume for it any other express warranty.

PLEASE SEND IN THE INCLUDED WARRANTY CARD WITHIN TEN (10) DAYS OF PURCHASE TO REGISTER YOUR UNIT WITH KEYS FITNESS PRODUCTS, LP. MADE IN THE USA. Thank you for your business! PLEASE MAIL WARRANTY CARD TO: KEYS FITNESS PRODUCTS, PO BOX 551239, DALLAS, TX 75355. Or online at www.keysfitness.com



Customer Service

(888) 340-0482

Keys Fitness Products

4009 Distribution Drive
Suite 250
Garland, TX 75041

www.keysfitness.com